

Good for maintenance – even better with monitoring!

FDT-based device and asset management software saves more than time and costs

To be competitive, high productivity and reliability are important factors. Use of an online diagnostic and monitoring system guarantees that all the functions of intelligent field devices can be exploited to the maximum. For this reason, Degussa uses FieldCare Professional software developed by Metso Automation for predictive maintenance, which significantly reduces shutdowns resulting from field device failure.

Numerous field devices have been in use for many years at Degussa C4-Chemie, the DWA facility for hydrogen production, which supplies its own site in Marl, Westphalia, Germany and other Degussa-owned production plants as well as non-Group companies. Because even planned shutdowns are kept as short and simple as possible, the task of preventing unplanned shutdowns, with their serious consequences, is of prime importance.

With this in mind, Degussa decided to install a system, which would exploit the full potential of modern field devices. Existing field devices, such as positioners and transmitters, offer the main required func-

tions – such as online parameter setting, online monitoring and comprehensive failure diagnostics. But now, every function of these devices can be used to the full by means of FieldCare Professional FDT-based online monitoring software: All the additional functions can now be used and potential failures can be recognized in good time. The inherent intelligence of the field devices is a prerequisite for the retroactive installation of the monitoring and automated failure recognition at an early stage.

All valves used in this Degussa facility are equipped with either ND800 or ND9000 intelligent HART-capable positioners from Metso Automation.

However, because HART-capable I/O cards in the process control system had not been installed earlier, Metso Automation technicians installed a HART Multiplexer network at the same time as the new monitoring software. The need for this facility – to avoid production shutdowns – was equally important during both installation and commissioning of the system.

FieldCare Professional runs on a standard computer supplied by Degussa. As its name implies, the software ‘takes care of’ the field devices and is based on FDT. As a user, Degussa can well appreciate the value of this open solution: Regardless of the vendor of the individual components, the system enables parameter setting and calibration as well as the diagnostics of any field device.

As a result, FieldCare supplies optimal information to the user during commissioning of the production process as well as during normal running and maintenance. The ability to manage all devices and different communication protocols by a single tool is worthy of the title ‘system’, which has become a reality thanks to Field Device Tool (FDT) and Device Type Manager (DTM) technology.



Degussa C4-Chemie (DWA installation for hydrogen production) supplies the company's site in Marl as well as other Degussa-owned production plants and non-Group companies with hydrogen.

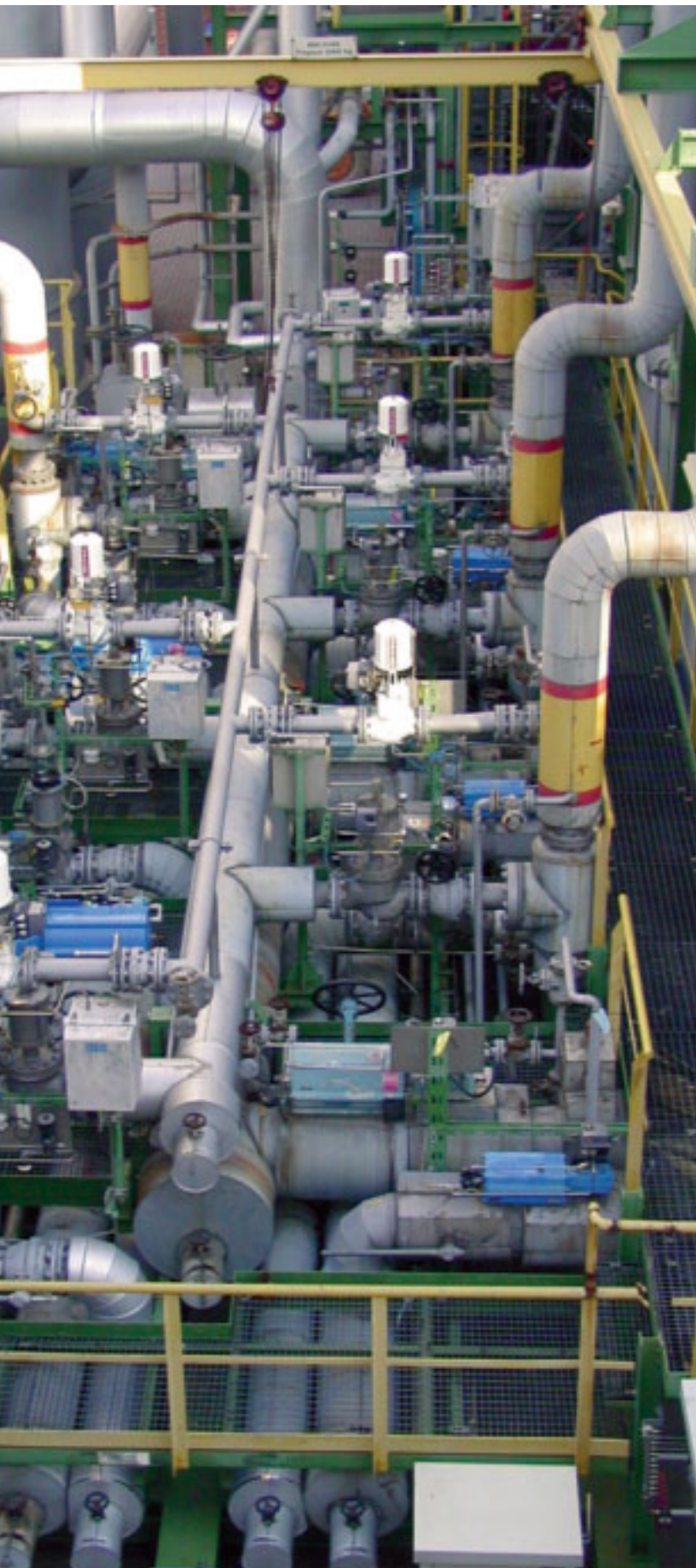

Fast access to all functions

The open and standardized communication platform FDT ensures the full functionality of field devices in a process control system (DCS) or a plant asset management system (PAM), regardless of vendors and communication protocols. At the same time, FDT supports all the major communication protocols (HART, Profibus, FOUNDATION Fieldbus). Now that they have installed FieldCare Professional software, Degussa can set parameters for both Profibus and HART devices. In the future, it will also be possible to use FOUNDATION Fieldbus devices.

Wherever intelligent field devices, such as valves, positioners and transmitters, are installed in a plant, the maintenance personnel receive all the important information on field devices via FieldCare Professional software.

In the overall concept of automated online monitoring, FieldCare provides the framework within which the appropriate Device Type Managers (DTM) can be used to enable the complete functional scope of all the field devices. The DTM displays all features of the devices: both standard configuration parameters and device-specific functions. For this reason, all device functions are now accessible, but the user no longer requires any vendor specific software.

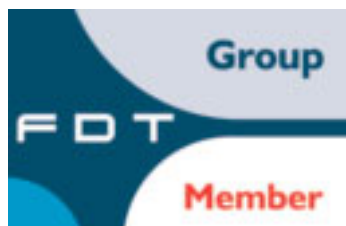

FDT (Field Device Tool) technology standardizes the communication interface between field devices and systems. The key feature is its independence from the communication protocol and the software environment of either the device or the host system. FDT allows any device to be accessed from any host through any protocol.

Degussa uses FieldCare software in order to exploit each field device to the maximum. The basis for this is the DTM, the graphical user interface for each field device, which ▶

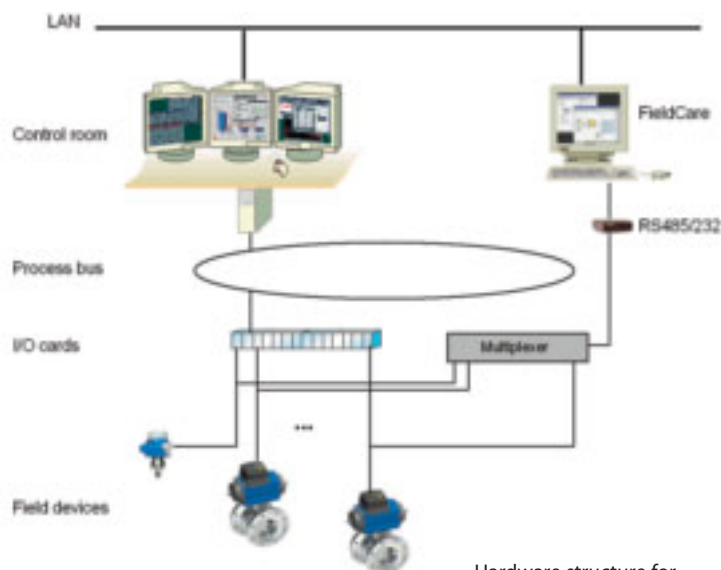

Hardware structure for active asset management.

▶ can be a device DTM or a communications DTM. To achieve optimal performance of the total system, all vendors of field devices deliver the appropriate DTM for each device, so that each DTM can be used in all DTM applications. This technology permits users to install a single tool for the total management of any field device from any vendor.

Simplifying the work and monitoring

Thanks to its numerous functions, FieldCare Professional software simplifies the everyday tasks of the user – ranging from the supervision of device condition to the configuration and planning of the network and process monitoring. Bus scanning, device recognition and DTM assignment follow automatically. The software offers further advantages, such as simultaneous access to several devices as well as uploading and downloading of the device configuration.

All device functions conform to DTM and all users' DTMs can be started from the FDT frame.

In large facilities it is not easy for users to keep the overall picture in mind, but FieldCare Professional offers valuable support. It indicates the online data flow of all devices by means of a color-coded alert system and a series of selective alarms.

The maintenance personnel can use the 'status monitor' for online monitoring. The current status of each field device is visualized by a characteristic color (for example 'OK' = green; Communication failure = blue; Warning = yellow; Device failure = red etc.) and enables direct access to all data stored in the database and in failure messages.

The user gets clear insight into process performance and can recognize potential problems quickly and easily. Moreover, all data is recorded for troubleshooting and technical support, and all monitored field devices can be included in a user-specific facility survey.

Preventing potential failures

With Condition Monitoring – online supervision – FieldCare Professional offers a central function

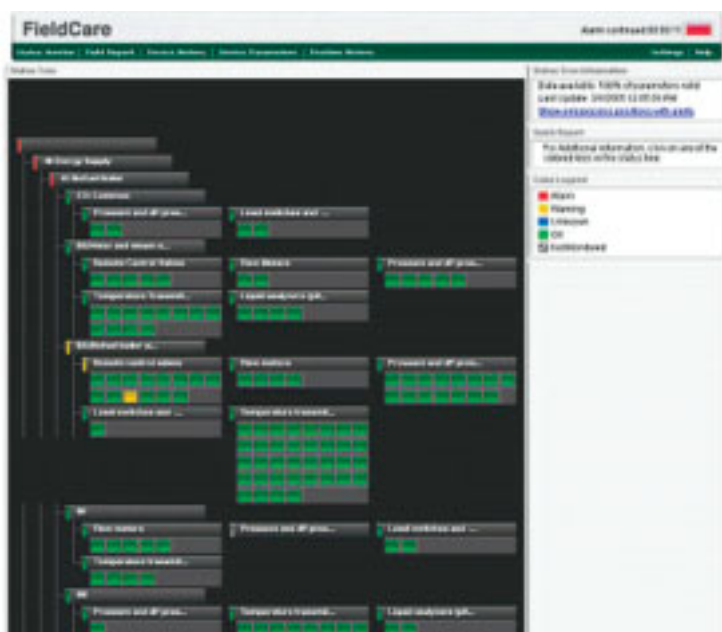

The Status Monitor is designed to visualize online monitoring for the maintenance personnel and to show potential failure in any field device.



FieldCare Professional FDT-based device and asset management software from Metso Automation has been successfully installed at Degussa C4-Chemie.

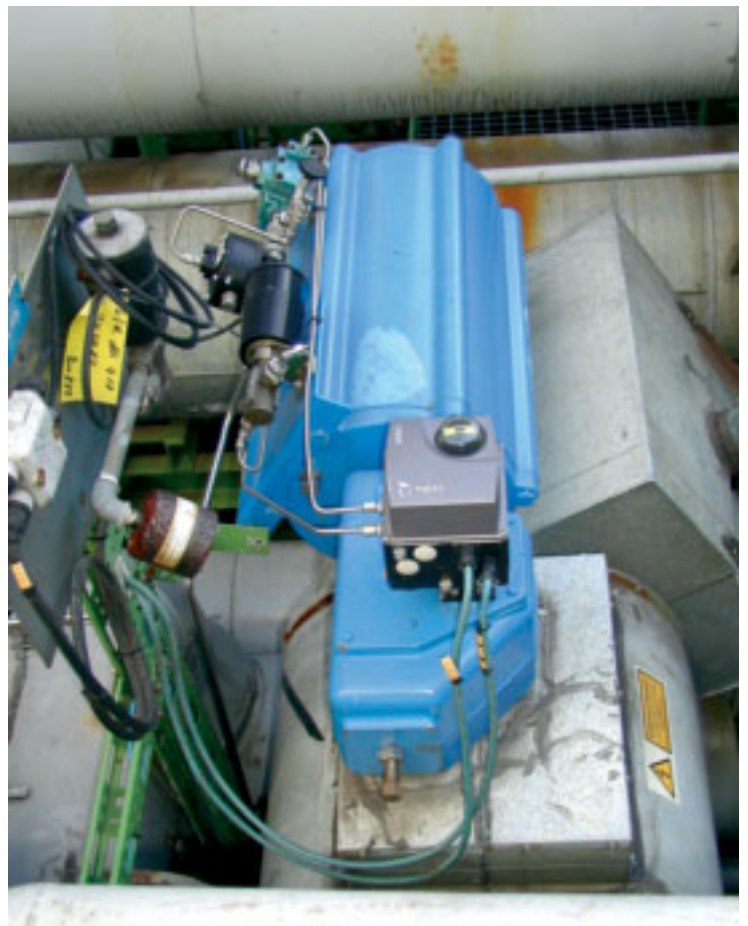

Because HART-capable I/O cards had not been previously installed, a HART Multiplexer network was installed at the same time as the FieldCare software.

Process tag LV-823 Time Span: 07.07.2002 - 07.08.2002

Bus type	Manufacturer	Device Model	Serial number
SMART	News Controls	ND009	64034

Report index

- 1. Device status history
- 2. Variable Report
- 3. Variables data

1. Device status history

Date	Status	Process Position	Device parameters
28.10.2002 10:52:21	Warning	LV-823	Deviation Problem
28.10.2002 10:34:50	OK	LV-823	
28.10.2002 10:34:34	Unknown	LV-823	Condition monitoring is starting
28.10.2002 10:31:34	Unknown	LV-823	Condition monitoring is not running
28.10.2002 10:30:34	Unknown	LV-823	Device has been assigned to process node

DeviceReport stores the complete history of each field device.

for the automatic reading of status messages from all field devices. The aim is to automate the questioning, analysis and storage of all important failure messages or alarm messages, as well as all diagnostic data, so that maintenance personnel receive specific information on the condition of the field devices before total breakdown occurs. The evaluation of the diagnostic data enables the operator to use predictive

maintenance, thanks to the early recognition of hidden faults. In addition, transient failures are recognized and reported.

These failure messages and alarm messages can be sent to the appropriate personnel by e-mail via the local network. Presentation of the condition monitoring data is provided in HTML so that Internet Explorer is applicable, i.e. no special software is needed. In addition, re-

Time Span 20.11.2002 14:47:49 - 27.11.2002 14:47:49

Date	Status	Process Position	Device parameters
27.11.2002 14:37:33	Alarm	LV-123	Travel Deviation User Limit Exceeded Travel Deviation Problem Travel Deviation Feed Limit Warning Travel Deviation Feed Limit Alarm
27.11.2002 14:37:10	OK	LV-123	
27.11.2002 14:37:24	Alarm	PI-101	Position ADC Saturation (d51 or d52) Denise in Fail-safe Mode Denise Failure
27.11.2002 14:36:49	Unknown	LV-123	Condition monitoring is starting
27.11.2002 14:36:10	Unknown	LV-123	Denise has been assigned to process node
27.11.2002 14:36:12	Unknown	PI-101	Condition monitoring is starting
27.11.2002 14:36:11	Unknown	PI-101	Denise has been assigned to process node

FieldReport shows all failures throughout the complete plant.

mote access is possible via the IE of each workstation in the LAN on the FieldCare computer. This provides flexible access to the data by a number of participants.

Thanks to this technology, the user not only has access to the status monitor, but also to other displays, such as FieldReport, DeviceReport and DeviceParameter. All failures throughout the facility are stored in FieldReport. The stored data includes date, time, number of measurement points, status and a resume of failure or alarm messages. DeviceReport contains the complete history of each field device, with all failure messages received during the monitoring period. Moreover, in DeviceParameter, statistical data and diagnostic data are stored, some in the form of graphics.

Increased operational reliability

By using FieldCare Professional, users like Degussa can profit not only from all the advantages of any device from any vendor but also from the corresponding tools for predictive maintenance. Intelligent field device management and the utilization of all vendor-specific functions can increase operational reliability and thereby improve efficiency. Moreover, central access to the online parameter setting of all field

devices virtually excludes failures in parameter setting, because the stored parameters are transferred, i.e. not reset. This procedure ensures greater security when field devices are replaced.

The automated display of all diagnostic data for predictive maintenance saves time and releases maintenance personnel for other duties. By using online monitoring, the performance of field devices is registered in real time, visually represented and reported by e-mail. The alerts take place before critical operational conditions occur. Therefore, shutdowns based on field device failure are avoided and the maintenance of the facility becomes scheduled. This is why FieldCare is much more than a tool for parameter settings; it offers 'active asset management'.



The DTM (Device Type Manager) encapsulates all the device-specific data, functions and business rules such as the device structure, its communication capabilities, internal dependencies, and the Human Machine Interface (HMI) structure. The DTMs provide functions for accessing device parameters, configuring and operating the devices, and diagnosing problems. DTMs can range from a simple Graphical User Interface (GUI) for setting device parameters to a highly sophisticated application capable of performing complex real-time calculations for diagnosis and maintenance purposes.

FOR MORE INFORMATION, PLEASE CONTACT:

Ulrich Gensicke,
Smart products specialist
Leverkusen, Germany
ulrich.gensicke@metso.com