

The SALA series of

Vertical sump pumps



Rubber lined & hard metal

Vertical sump pumps

All Metso Sump Pumps are designed specifically for abrasive slurries and feature a robust design with ease of maintenance. Developed from the old SALA sump pump, VASA G model, the

Metso type VS vertical sump is the next generation heavy duty sump pump.

Like its predecessor, the VS sump pump is one of the strongest, toughest and most reliable available on the market. For this reason the VS is preferred throughout the world by most heavy industries.

Pump designation

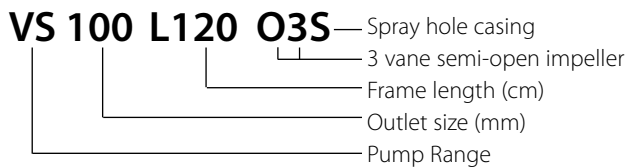

Pump designation

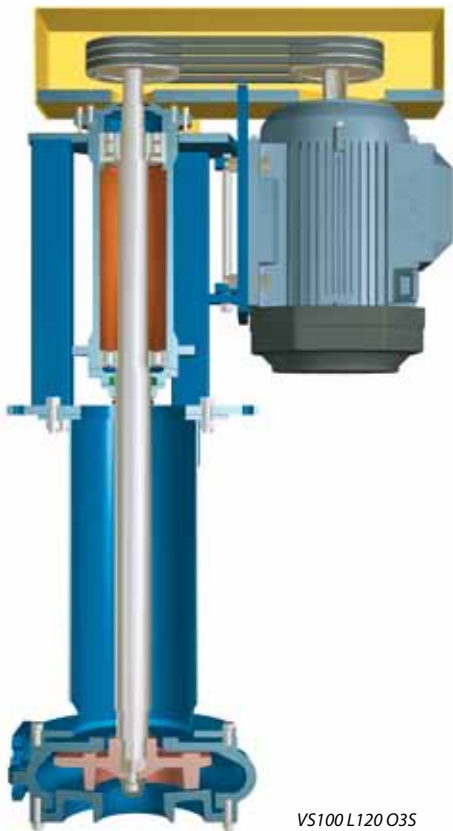
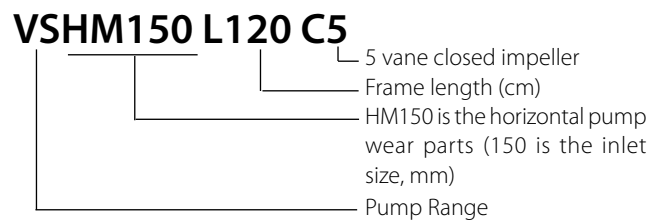

VS100 L120 O3S



VSHM150 L120 C5

Simple installation

With small sump pumps it is possible to hang the pump in the sump by the lifting bracket provided. Larger units are normally bolted to a permanent base plate. Pump bearings are located in a housing above the base plate for accessibility and protection. All pumps can run dry intermittently. Pumps with metal pump parts can run dry for an unlimited length of time. Special designs giving extended length, with the bearings below the base plate, are available on request.

Cantilever design

The heavy duty pump shaft is of cantilever design, hanging below the bearing housing. There are no submerged bearings, stuffing box or shaft seals. This design ensures minimum maintenance and eliminates the need for water flushing. The pump shaft is mounted in grease lubricated roller bearings. Impeller clearance is maintained by external axial adjustment of the shaft/bearing assembly. Bearings have double seal protection against contamination.

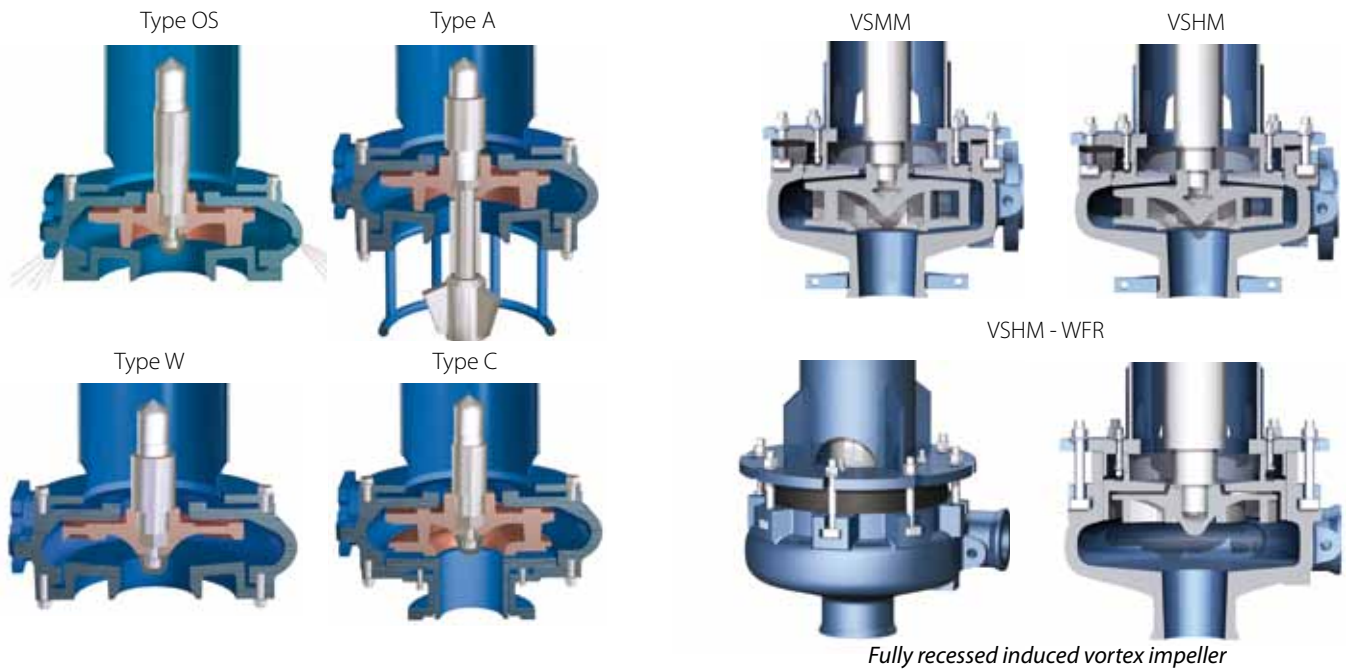

Details of design features

Impeller and agitation options VS

Four different impeller and two agitation options are available for optimum performance.

Type O – The semi-open impeller provides better solids handling than the closed impeller design and is less sensitive to air blocking on intermittent operation.

Type W – Vortex induced flow impeller for clogless pumping of long fibrous or coarse solids. It can be fitted into a casing with or without spray holes. Large clearance between casing and impeller – well suited for pumping fibrous slurries (paper stock, wood chips, municipal sludge, etc.), aerated or frothy liquids (vortex impeller will not be air blocked) and any application where the pump is required to pass the occasional large solids.

Type WFR – We have developed a fully recessed induced vortex impeller for the VSHM pumps. This is specifically designed for carbon transfer in gold leaching processes because it provides the lowest possible attrition of the pumped active carbon particles.

Type C – Closed impeller for higher heads and efficiencies. Can not be combined with type S, casings with spray holes.

Type A – Semi-open impeller and robust extended shaft with a slurry agitator. This design is best suited for coarse rapid settling solids and dredging type applications.

Type S – Pump casing with spray holes. The spray holes direct some of the slurry towards the sump bottom, thereby agitating settled solids. Available from VS50 to VS200.

Wet end

The “wet end” parts have large material sections for extra long wear life and are designed for the toughest of applications. Single volute and generous solids passage through the pump ensure safe and clogless operation. The “wet end” assembly is suspended from a tubular column below the bearing housing.

Materials

Standard pumps are supplied with parts in wear resistant natural rubber or High Chrome white iron alloy, with a nominal hardness of 600 BHN.

Other wear part materials available include elastomers in synthetic rubbers and polyurethane and metals such as 316 stainless steel and CD4MCu.

Parts in different materials are fully interchangeable and can be combined for optimum life.

The VSH and VSM pumps are a new combination of our classic VS sump pumps and our Orion series horizontal pump wet ends.

This provides a major advantage to the customer: the same wet end parts are used for both horizontal slurry pumps and sump pumps, thus reducing parts inventory and simplifying maintenance. It does also make it possible to generate a higher TDH, pump head.

Typical sump pump applications

- Floor sumps in process plants
- Mill scale pumping in steel work
- Pumping of machine tool cuttings
- Wood chips pumping

Drive

Pumps can be supplied with a V-belt drive, motor and drive guard. The motor is mounted vertically, on an adjustable motor plate fitted beside the bearing housing.

Motor Size

Motor size and V-belt drive vary with the pump application. Minimum data required for an approximate pump, speed and drive motor selection are:

- Slurry flow rate
- Slurry density
- Total discharge head

Summary of design features

- Simple installation
- Cantilever design without submerged bearings or shaft seal
- Bearing assembly with double protection sealing arrangement to prevent bearing contamination
- Materials used are the very best available, providing both excellent wear properties and corrosion resistance
- Wear parts are available in a variety of different materials and fully interchangeable
- Range of impeller and casing options



VSHM 100 E250 C5 is a special design type with "E" extended shaft



Acid proof version with all wetted parts fully covered with natural rubber or chloroprene.

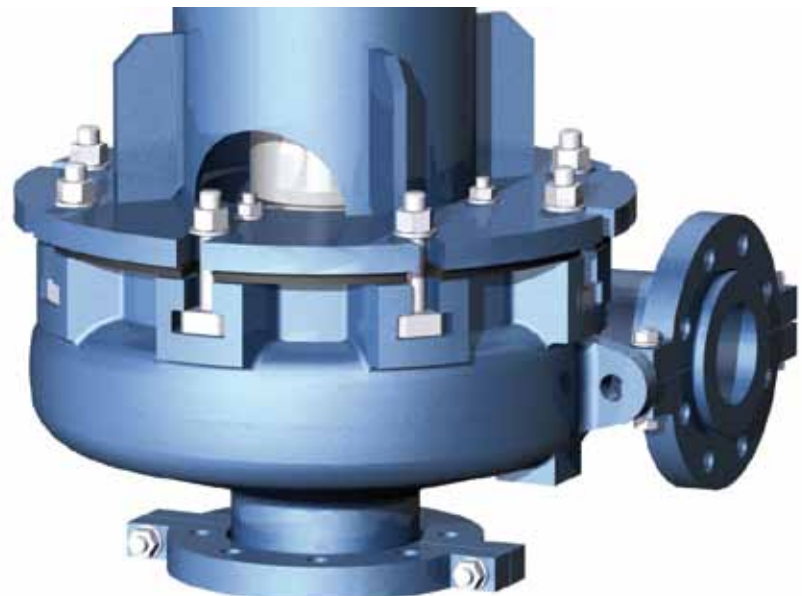

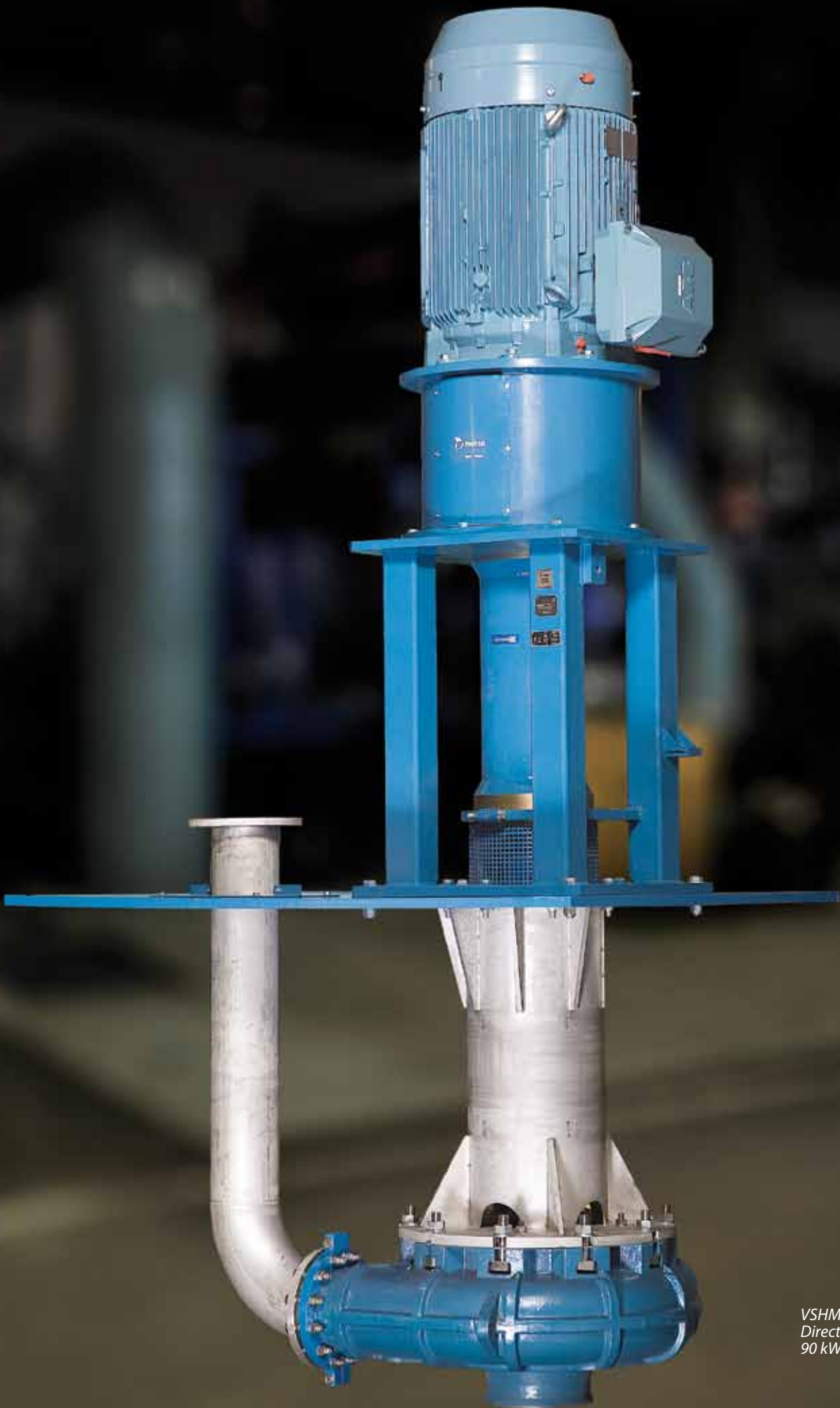

VSHM 250 L150
Direct Drive,
90 kW, 8-pole motor

Selection of pump size and pump dimensions vs vertical sump pump range

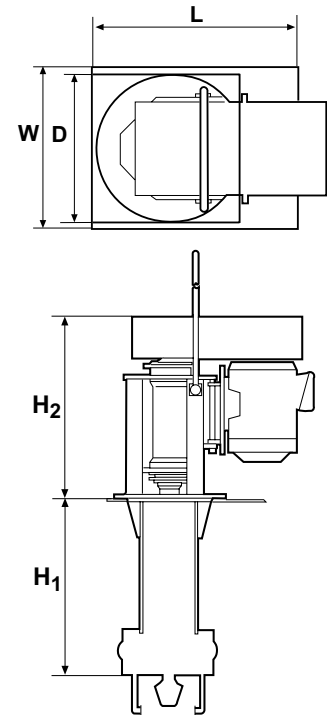
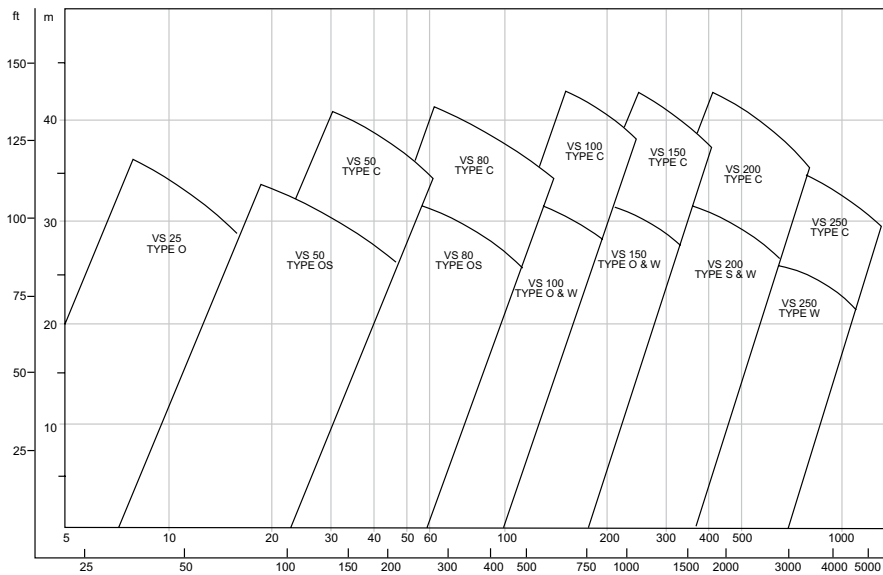

Pump Size	Outlet* inch	H ₁		H ₂		D		L Opt. base plate		W		Weight ***		Weight Opt. base plate	
		cm	inch	mm	inch	mm	inch	mm	inch	mm	inch	kg	lb	kg	lb
VS25	1	800	32	585	23	∅ 400	15 ³ / ₄	450	17 ³ / ₄	450	17 ³ / ₄	130	287	11	24
VS25	1	1 200	48	865	34	∅ 530	20 ³ / ₄	600	23 ¹ / ₂	600	23 ¹ / ₂	350	772	27	60
VS25	1	1 500	60	865	34	∅ 530	20 ³ / ₄	600	23 ¹ / ₂	600	23 ¹ / ₂	375	827	27	60
VS25	1	1 800	72	865	34	∅ 530	20 ³ / ₄	600	23 ¹ / ₂	600	23 ¹ / ₂	395	871	27	60
VS50●	2	800	32	585	23	∅ 400	15 ³ / ₄	600	23 ¹ / ₂	600	23 ¹ / ₂	220	485	30	66
VS50●	2	1 200	48	865	34	∅ 530	20 ³ / ₄	600	23 ¹ / ₂	600	23 ¹ / ₂	480	1 058	27	60
VS50●	2	1 500	60	865	34	∅ 530	20 ³ / ₄	600	23 ¹ / ₂	600	23 ¹ / ₂	510	1 124	27	60
VS50●	2	1 800	72	975	38	∅ 565	22 ¹ / ₄	600	23 ¹ / ₂	600	23 ¹ / ₂	540	1 190	27	60
VS80	3	800	32	870	34	∅ 530	20 ³ / ₄	600	23 ¹ / ₂	600	23 ¹ / ₂	415	915	31	68
VS80●	3	1 200	48	975	38	∅ 565	22 ¹ / ₄	600	23 ¹ / ₂	600	23 ¹ / ₂	530	1 168	31	68
VS80●	3	1 500	60	975	38	∅ 565	22 ¹ / ₄	600	23 ¹ / ₂	600	23 ¹ / ₂	565	1 245	31	68
VS80●	3	1 800	72	975	38	∅ 565	22 ¹ / ₄	600	23 ¹ / ₂	600	23 ¹ / ₂	600	1 322	31	68
VS100	4	800	32	850	33	∅ 530	20 ³ / ₄	750	29 ¹ / ₂	600	23 ¹ / ₂	435	959	45	99
VS100●	4	1 200	48	960	37	∅ 565	22 ¹ / ₄	750	29 ¹ / ₂	600	23 ¹ / ₂	550	1 212	45	99
VS100●	4	1 500	60	960	37	∅ 565	22 ¹ / ₄	750	29 ¹ / ₂	600	23 ¹ / ₂	585	1 289	45	99
VS100●	4	1 800	72	960	37	∅ 565	22 ¹ / ₄	750	29 ¹ / ₂	600	23 ¹ / ₂	620	1 366	45	99
VS150●	6	1 200	48	965	38	∅ 565	22 ¹ / ₄	900	35 ¹ / ₂	750	29 ¹ / ₂	645	1 422	80	176
VS150●	6	1 500	60	1 285	50	□ 800	31 ¹ / ₂	1 200	47 ¹ / ₂	900	35 ¹ / ₂	1 370	3 019	140	309
VS150●	6	1 800	72	1 285	50	□ 800	31 ¹ / ₂	1 200	47 ¹ / ₂	900	35 ¹ / ₂	1 425	3 141	140	309
VS200●	8	1 200	48	1 285	50	□ 800	31 ¹ / ₂	1 200	47 ¹ / ₂	900	35 ¹ / ₂	1 610	3 548	172	379
VS200●	8	1 500	60	1 285	50	□ 800	31 ¹ / ₂	1 200	47 ¹ / ₂	900	35 ¹ / ₂	1 660	3 659	172	379
VS200●	8	1 800	72	1 285	50	□ 800	31 ¹ / ₂	1 200	47 ¹ / ₂	900	35 ¹ / ₂	1 710	3 769	172	379
VS250	10	1 500	60	1 420	56	□ 800	31 ¹ / ₂	1 360	53 ¹ / ₂	1 220	48	2 200	4 850	265	584
VS250	10	1 800	72	1 420	56	□ 800	31 ¹ / ₂	1 360	53 ¹ / ₂	1 220	48	2 280	5 027	265	584

*VS25 1 : VS = Vertical Sump; 25 = outlet mm; 1 = outlet inch

** D ∅ or □ is bearing frame base plate. Larger optional base plate or mounting plate incl. discharge pipe also available.

*** Weight figures are for metal parts type O & W. For rubber parts reduce weight by approx. 10%.

● These pumps are available in acid proof version with all wetted parts fully covered with natural rubber or chloroprene.

Selection of pump size and pump dimensions vsh, vsm vertical sump pump range

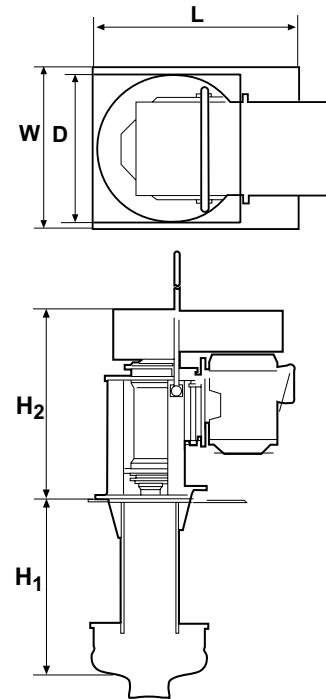
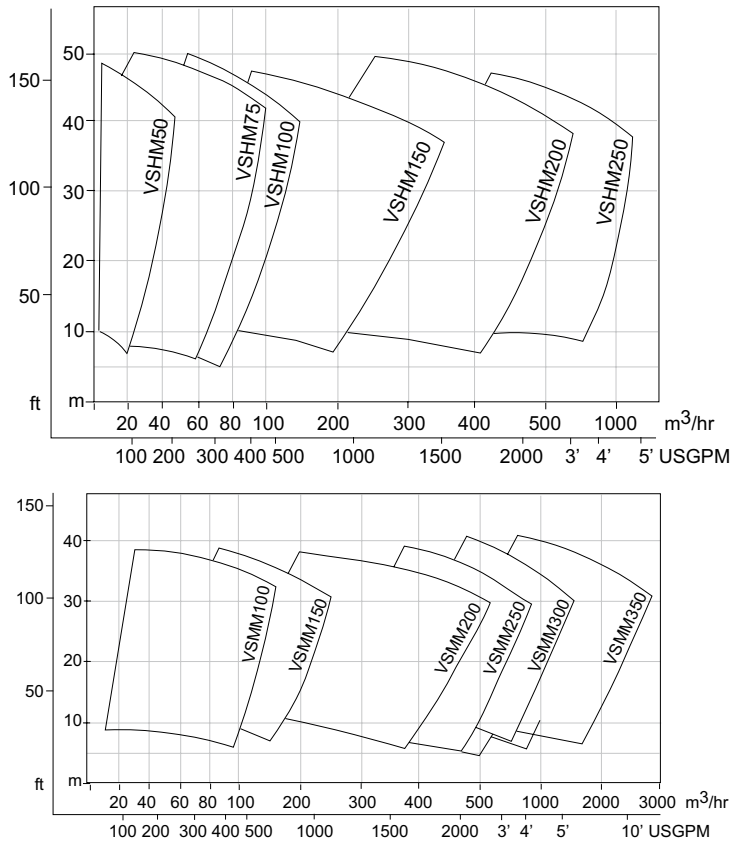

Pump Size	Outlet		H ₂		D*		L Opt. base plate		W		Weight **	
	mm	inch	mm	inch	mm	inch	mm	inch	mm	inch	kg	lb
VSHM50 ●	32	1,25	870	34	∅ 530	20 ¾	600	23 ½	600	23 ½	390/405/420	860/893/926
VSHR50	32	1,25	870	34	∅ 530	20 ¾	600	23 ½	600	23 ½	380/395/410	838/871/904
VSHM75 ●	50	2	870	34	∅ 530	20 ¾	600	23 ½	600	23 ½	(L120) 415	915
VSHR75	50	2	980	38	∅ 565	22 ¼	600	23 ½	600	23 ½	(L150 / 180) 530/565	1168/1245
VSHM100 ●	75	3	870	34	∅ 530	20 ¾	600	23 ½	600	23 ½	399/424/449	880/935/990
VSHR100	75	3	980	38	∅ 565	22 ¼	750	29 ½	600	23 ½	535/565/605	1180/1246/1334
VSHM150 ●	100	4	980	38	∅ 565	22 ¼	750	29 ½	600	23 ½	555/585/625	1224/1290/1378
VSHR150	100	4	1280	50	□ 800	31 ½	1200	47 ¼	900	35 ½	1314/1366/1418	2897/3012/3127
VSHM200	150	8	1280	50	□ 800	31 ½	1200	47 ¼	900	35 ½	1405/1460/1515	3098/3219/3340
VSHR200	150	8	1280	50	□ 800	31 ½	1200	47 ¼	900	35 ½	1650/1710/1770	3638/3770/3903
VSHM250	200	10	1280	50	□ 800	31 ½	1200	47 ¼	900	35 ½	1680/1740/1796	3704/3836/3960
VSHR250	200	10	1420	56	□ 800	31 ½	1200	47 ¼	900	35 ½	1680/1740/1796	3704/3836/3960
VSHM300	200	10	1420	56	□ 800	31 ½	1360	53 ½	1220	48	2310/2400/2480	5093/5291/5468
VSHR300	200	10	1420	56	□ 800	31 ½	1360	53 ½	1220	48	2365/2455/2535	5214/5413/5589
VSM100 ●	75	4	870	34	∅ 530	20 ¾	600	23 ½	600	23 ½	430/465/500	948/1025/1103
VSM150 ●	100	6	980	38	∅ 565	22 ¼	750	29 ½	600	23 ½	560/590/630	1235/1301/1389
VSM200 ●	150	8	980	38	∅ 565	22 ¼	750	29 ½	600	23 ½	1390/1445/1500	3065/3186/3307
VSM250	200	10	1280	50	□ 800	31 ½	1200	47 ¼	900	35 ½	1720/1780/1840	3792/3925/4057
VSM300	200	12	1420	56	□ 800	31 ½	1360	53 ½	1220	48	2490/2570/2650	5490/5666/5843
VSM350	300	14	1420	56	□ 800	31 ½	1360	53 ½	1220	48	- /2745/2825	- /6052/6228

Frame length (H₁) is available in 120, 150, 180 cm (48, 60, 72 inch) except VSMM350 which is available in 150, 180 cm (60, 72 inch).

* D ∅ or □ is bearing frame base plate. Larger optional base plate or mounting plate incl. discharge pipe also available.

** Weight figures are for metal parts, and for different frame lengths (L120 / L150 / L180).

● These pumps are available with the fully recessed induced vortex impeller.

- **Metso Minerals (Sweden) AB**
Norrängsgatan 2, SE-733 38 Sala, Sweden, Phone: +46 224 374 00, Fax: +46 224 169 69
- **Metso Minerals Industries Inc.**
621 South Sierra Madre, Suite #100, Colorado Springs, CO 80903, USA, Phone: +1 719 471 3443, Fax: +1 719 471 4469
- **Metso Minerals Industries Inc.**
P.O. Box 96, Birmingham, AL 35201, USA, Phone: +1 205 599 6600, Fax: +1 205 599 6623
- **Metso Minerals (South Africa) (Pty) Ltd.**
Private Bag X2006, Isando, Johannesburg, 1600, South Africa, Phone: +27 11 961 4000, Fax: +27 11 397 2050
- **Metso Minerals (Australia) Ltd.**
Level 2, 1110 Hay Street, West Perth, WA 6005, Australia, Phone: +61 8 9420 5555, Fax: +61 8 9320 2500
- **Metso Minerals (India) Pvt Ltd**
1th floor, DLF Building No. 10, Tower A, DLF Cyber City, Phase - III, Gurgaon - 122 002, India, Phone: +91 124 235 1541, Fax: +91 124 235 1601
- **Metso Perú S.A.**
Calle 5 Nro. 144, Urb. Industrial Vulcano, Ate, Lima 03, Peru, Phone: +51 1 313 4366, Fax: +51 1 349 0913
- **Metso Minerals (Chile) S.A.**
Av. Los Conquistadores 2758, - Piso 3, Providencia, Santiago, Chile, Phone: +56 2 370 2000, Fax: +56 2 370 2039
- **Metso Brasil Indústria e Comércio Ltda.**
Av. Independência, 2500 Éden, 18087-101 Sorocaba-SP - Brazil, Phone: +55 15 2102 1300



www.metso.com
E-mail: minerals.info@metso.com
Pumps information at
www.metso.com/pumps