

Metso

Double, single and low dilution

Mechanical slurry seals



Seals designed for Metso slurry pumps

Metso offers a complete line of slurry pump mechanical seals to satisfy most slurry transport applications in a wide range of industries.

Mechanical seals are typically applied to slurry pump applications when:

- Water conservation is a concern
- Zero leakage of water out of the pump is required
- No dilution water into the process is allowed
- Traditional packing and shaft sleeve life fail prematurely
- Operating cost must be reduced

The BF and BA unique designs provide excellent results in all light to heavy slurry grades HI (Hydraulic Institute).

The ESF design seals satisfy the demand for advanced and reliable sealing solutions on even the heaviest of slurry applications typically found in mining applications.

With many years of application experience, we can facilitate the best seal selection for your unique application.

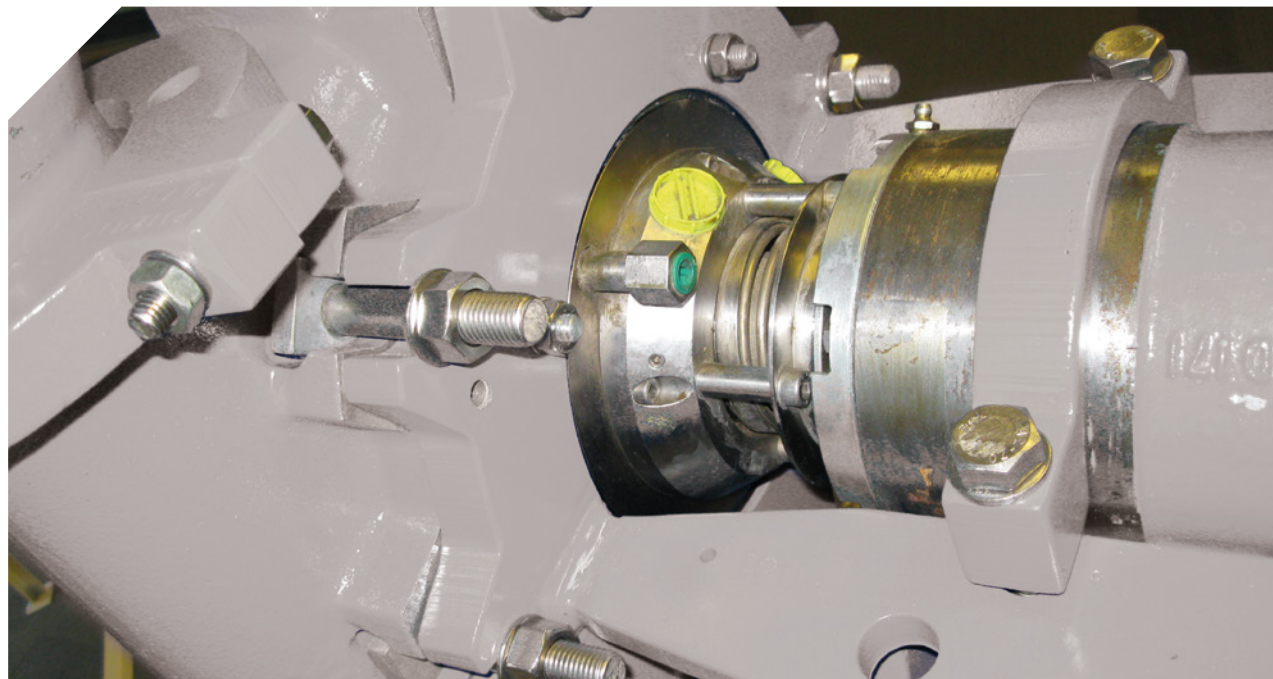

BF - Single mechanical cartridge seal

- Where environmental issues require zero leakage of gland water
- Water and dirty water applications – Hydraulic Institute Service Class 1
- Pump is continuously operated on a positive inlet pressure
- Axially self adjusting

Typical applications

Mildly abrasive slurries (HI Service class 1)

- Mine dewatering
- Waste water handling
- Mildly abrasive industrial minerals

BA - Double mechanical cartridge seal

- Down to 5 μ particle size distribution – especially good in ultra fine particle applications
- High pressure and/or high temperature applications
- Axially self adjusting

Typical applications

Abrasive slurries (HI Service class 1-2) High solids concentration installations

- General mineral processing
- Abrasive industrial minerals
- Hazardous liquids
- Applications requiring double seal to prevent leakage to atmosphere

ESF - Single mechanical seal – fits into existing gland housing

- Replace pump packing seals in existing gland housing

Typical applications

Abrasive slurries (HI Service class 1-4) High solids concentration installations

- Filter feed
- Cyclone feed
- Mill discharge

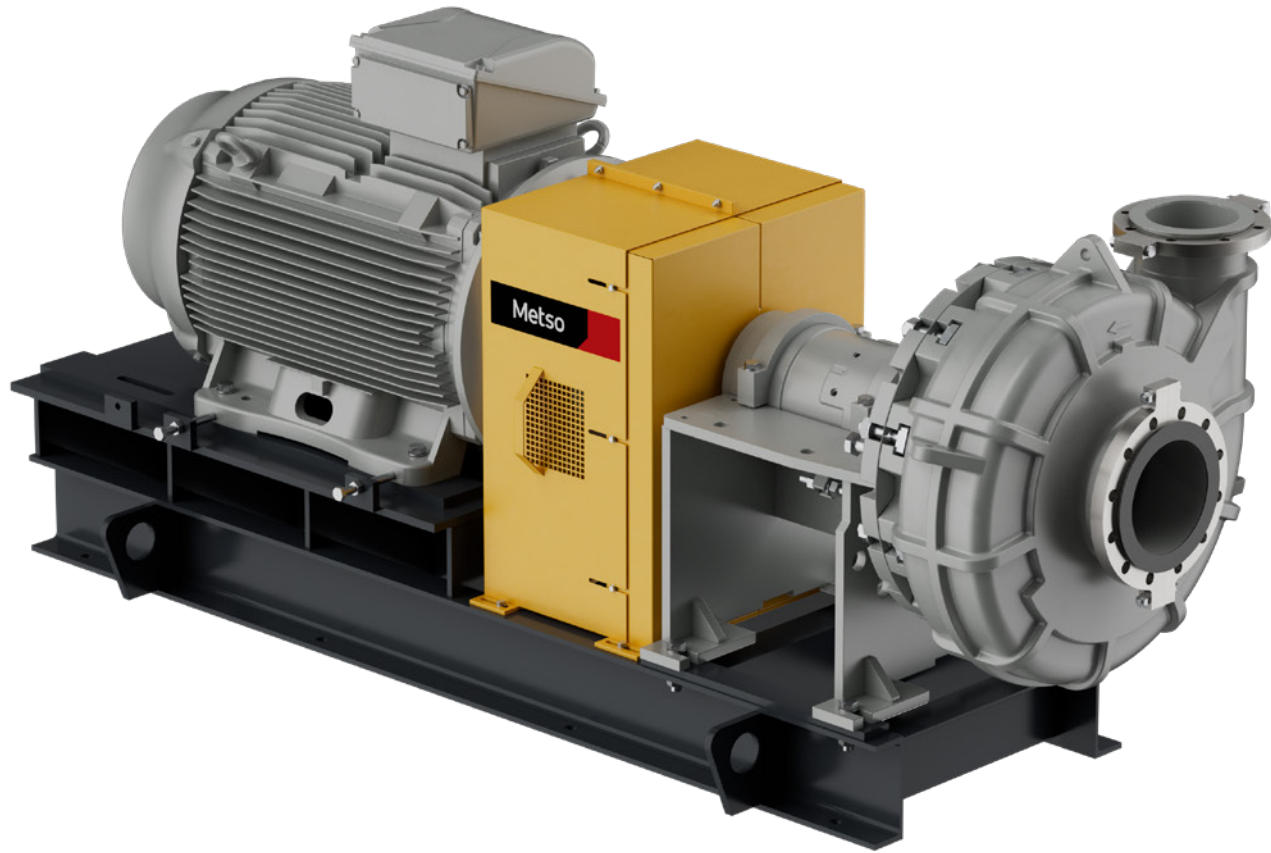

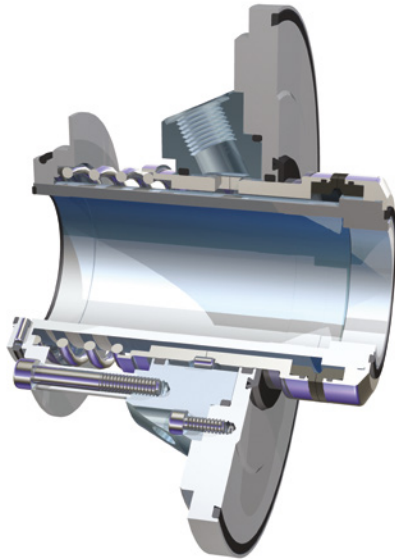

BF Single face seal

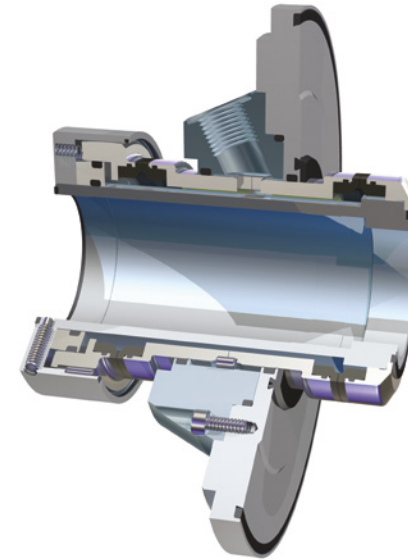

BA Double face seal

Features and benefits BF and BA seals

Cartridge design to fit the Orion Series

- Easy to install into a new or retrofit pump application.

Integral seal plate

- Plug-and-play seal reduces cost and time of installation.

Axial adjustment

- Pump impeller to case clearance can be easily adjusted to optimize pump performance without face isolation.

Silicon Carbide seal faces

- Excellent seal face life for most slurry applications. pH 1 – 14.

Optional face materials

- Tungsten Carbide and Diamond coating – improves performance on heavy duty slurry applications.

O-ring mounted seal faces

- Seal faces can be replaced in the field without special tools to reduce repair cost.

Patented - protected side compression springs (BA seal only)

- Springs provide constant compressive pressure on seal faces and are protected from both slurry and barrier fluid.

Barrier fluid flush port

- Lubricating and cooling fluid protects against dry running and prevents solids incursion between seal faces. Many barrier fluid systems are available to optimize applications.

Special wiper seal

- Protects the O-rings and grooves from abrasive slurry.

Upgradeable

- Single seal can be upgraded to double seals with minimal components added.

Zero flush

- No barrier fluid requirement on BF seal.

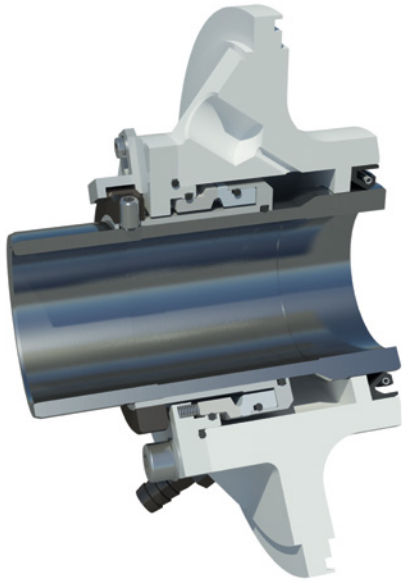

ESF Single face seal

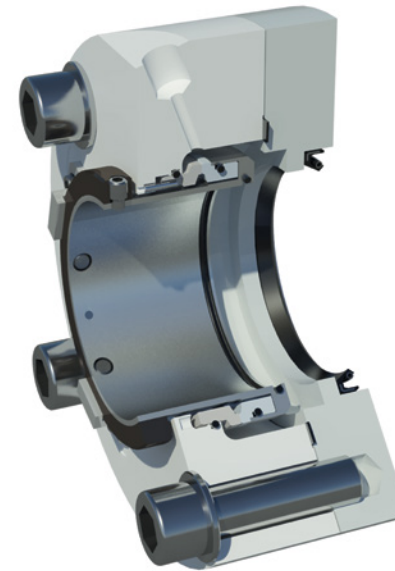

ESF Seal for VASA HD pumps

Features and benefits EFS seals

Cartridge design – Easy to install

- The ESF seal is designed to fit into the standard Orion Series pump flushed gland housing. For the VASA HD a convenient seal adaptor is used.

Retrofit packing

- Retrofit installations are quick and easy when converting a packed seal pump. Plug-and-play.

Tungsten Carbide seal faces are standard

- Longer life for the tougher applications

Flushed gland port

- This port along with the internal chamber creates a barrier of clean continuously replenished fluid to prevent incursion of slurry material to the seal faces which increases service life of the seal.

Centering clip

- Centering clips are self storing and are used to keep the seal faces in position when impeller to casing clearance is adjusted.

Radial lip seal

- To ensure that the seal runs in a clean water environment.

O-ring mounted seal faces

- Seal faces can be replaced in the field without special tools to reduce repair cost.

Mechanical seal accessories

Barrier fluid systems

Barrier fluid systems come in many configurations to satisfy a wide range of mechanical seal applications. The BA and BF mechanical seal may be combined with a special Thermosiphon system that circulates liquid due to the temperature difference of the sealing liquid inside the seal and in the tank, thus providing lubrication and cooling for the seal faces. To induce even more liquid to circulate and hence increase the cooling effect, the seal should be equipped with a pumping ring inside the seal. The pump operating pressure, the slurry being pumped and seal type will dictate the barrier fluid system requirements.

Flow monitoring package

The device consists of a constant flow valve, flow indicator and check valve. This package allows for easy to monitor, trouble-free seal flushing.



Flow monitoring device



Repair kits -
available for
convenient repair
of seal on site



ESF wet side



BF wet side



BA wet side



ESF dry side



BF dry side



BA dry side

Metso is a frontrunner in providing sustainable technologies, end-to-end solutions and services for the aggregates, minerals processing and metals refining industries globally. By helping our customers increase their productivity, improve their energy and water efficiency and environmental performance with our process and product expertise, we are the **partner for positive change.**

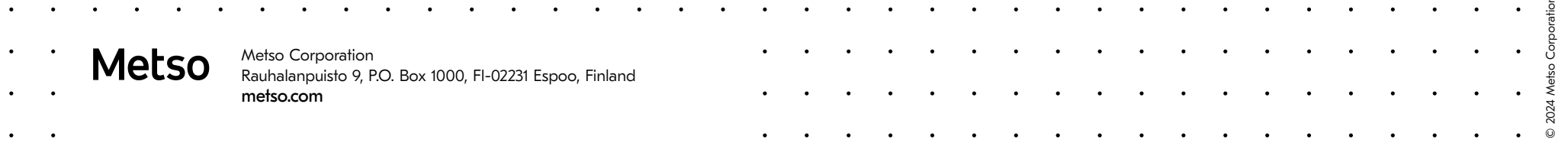

Metso

Metso Corporation
Rauhalanpuisto 9, P.O. Box 1000, FI-02231 Espoo, Finland
metso.com