

Minerals Processing Solutions

Copper
Sungun

Customer: Iran. Ministry of Mines and Metals.
NICICO (National Iranian Copper Ind. Co.)

Project type: Greenfield

Plant: Sungun, Iran

Ore: Copper Ore, average feed grade 0,7 %Cu

Scope of supply: Primary Mill feed rate: 900 MTPH
Concentrate production: 30 MTPH.

Equipment & Processes: Metso supplies of all major process plant equipment, basic plant engineering, including control system configuration and programming.
Metso review of locally made detail eng. for provision of complete process plant guarantee. Project included project management & site management for erection/commissioning, with hand-over after successful performance test.
Primary crusher, s-54-75
Feeders and screens
Primary SAG mill, 9,75 m x 4,90 m, 2 x 4100 kW
Secondary ball mills, 2 units x 6,10 m x 9,30 m, 6000 kW
Regrind ball mill, 4,00 m x 5,80 m, 1250 kW
Rougher flotation cells, 12 units RCS130
1:st cleaner flotation cells, 2 units, column 4 m x 12 m
2:nd cleaner flotation cell, column 4 m x 9 m
Cleaner scavenger flotation cells, 4 units x RCS 50 m³
Concentrate thickener, dia. 12 m
Concentrate pressure filters, 2 units VPA



1,5 x 1,5 m with 46 chambers
Tailings thickener, dia. 45 m
Conditioners and surge tanks
Slurry pumps
Slurry rubber lined and rubber hose piping
Spare and wear parts for commissioning and 2 years of operation
Off-site and on-site training
Erection and commissioning supervision
Complete greenfield project at north-west border of Iran at +2000 m altitude.

Comments:

Benefits:

Metso responsible for process design, equipment selections and process systems & controls configuration, to enable complete process performance guarantees.

Year: 2006.

www.metso.com
E-mail: minerals.info@metso.com



Minerals Processing Solutions

Copper Sungun

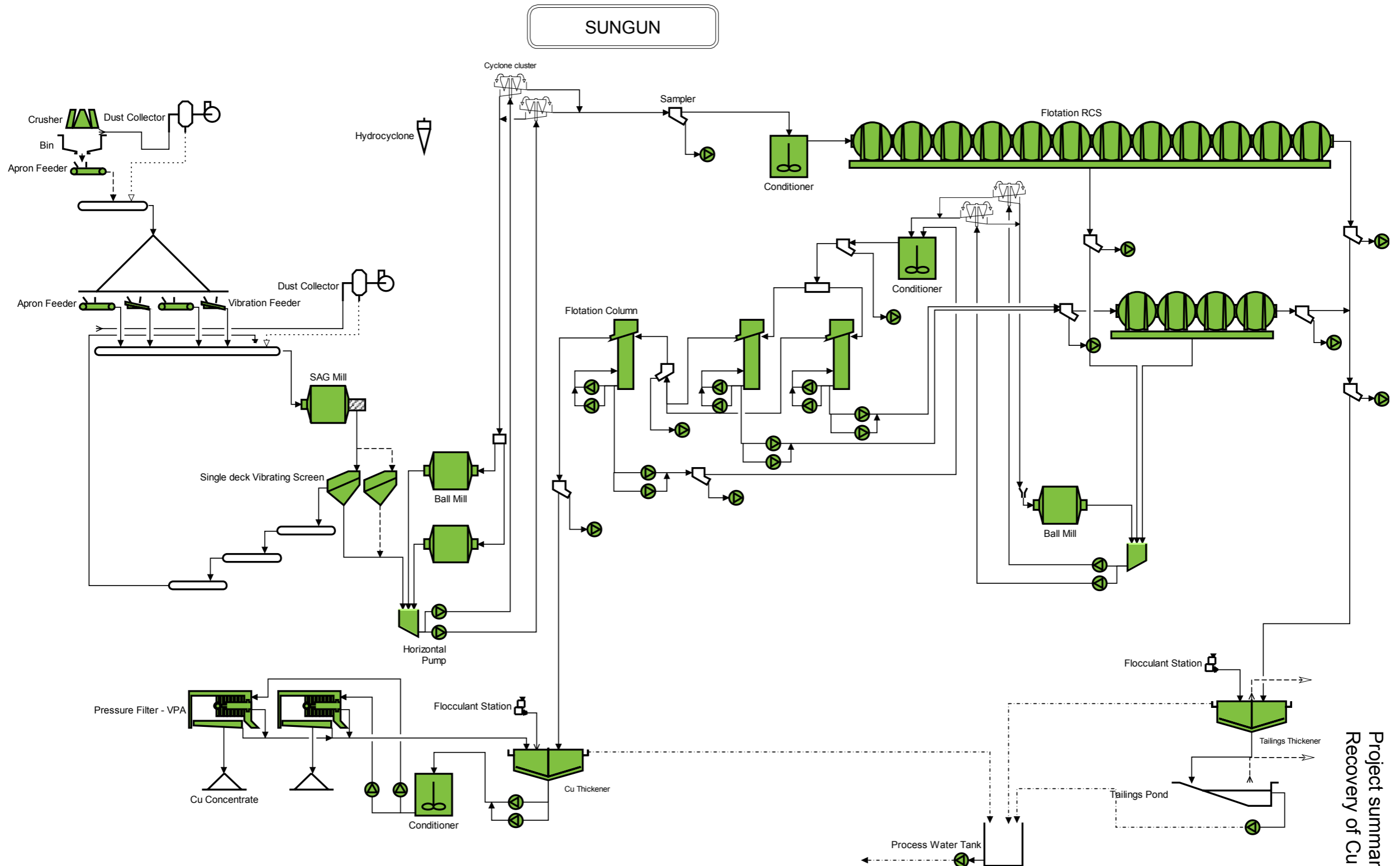

Project summaries
Recovery of Cu ore